

23. Ensure power is stable and continuous:
 - a All welding near the fixture must be complete.
 - b Junction box doors are closed.
24. Connect 9-position (data-in) elec. input connector to electronics plate.
25. Install stanchion cap. Secure cap by tightening four screws in an alternating cross pattern.

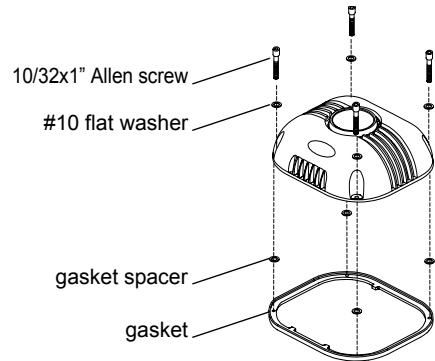

Note: Ensure #10 washers and gasket spacers are installed as pictured above.

Power Up and Final focus

26. Apply power to start lamp.

Note: The luminaire automatic calibration process will drive all filters to an open position. The luminaire will remain in this state until data is present. Allow seven minutes for lamp to reach full operating temperature.

23. Focus luminaire as follows:

- a Tilt head assembly to adjust for elevation.
- b Turn stanchion to adjust left/right orientation.
- c Tighten Allen head screw in tilt tube clamp securely.
- d Power unit off.
- e At remote head mount assembly, tighten 1-1/4 inch nut securely. Tilt tube clamp should hold head in place while tightening.
- f Replace large cover (ensure o-ring forms good seal).

Sample wiring riser

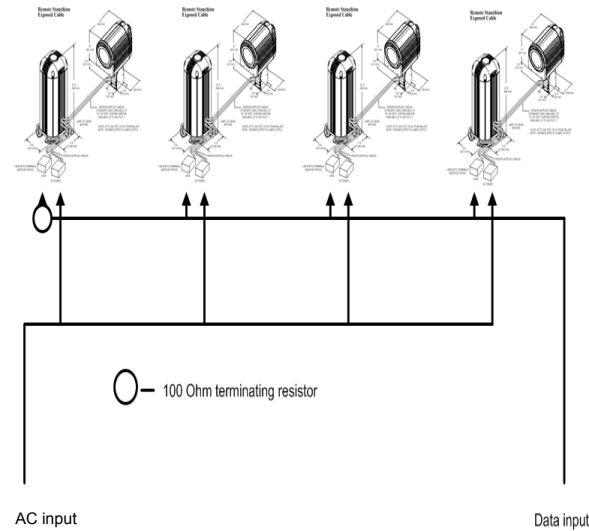

Technical Assistance

The **AR500** is a low maintenance luminaire, but in the event of malfunction, troubleshooting and repair procedures have been included in the owners manual. For further assistance regarding the **AR500** luminaire please contact Electronic Theatre Controls Technical Support staff at one of the offices identified below.

Americas

ETC Americas
 Technical Services Department
 3030 Laura Lane
 Middleton, WI 53562
 Toll Free (800) 775-4382
 or (608) 831-4116
 email: service@etcconnect.com

Europe

ETC Europe Ltd.
 Technical Services Department
 5 Victoria Industrial Estate
 Victoria Road,
 London W3 6UU England
 phone: +44 (0)208 896 1000
 email: service@etc europe.com

Asia

ETC Asia, Ltd.
 Technical Services Department
 Room 605-606
 Tower III, Enterprise Square
 9 Shueng Yuet Road
 Kowloon Bay, Kowloon, Hong Kong
 phone: +852-2799-1220
 email: service@etcasia.com

IRIDEON™ AR500™ Exterior Wash Luminaire Installation Sheet - Remote Version

Before Starting

The **AR500** luminaire head and stanchion are packed in two separate cartons. Lamps (if purchased), manuals, full lens set, tool kit and accessories are packed in a third box. The tool kit (part# 7091K4018) includes the following items:

- 3/16 inch T-handle Allen wrench
- 100Ohm Termination resistor

Items also required, but not supplied:

- #2 Phillips screwdriver
- 5/32" Allen Wrench
- 3/4" socket driver
- 9/16 inch (or 15mm) Socket and ratchet
- Two waterproof junction boxes with terminal strips (or one barriered waterproof junction box) for each luminaire.
- Stanchion mounting hardware: 4 each 3/8-18 or M10 studs, nuts, flat and lock washers.
- Remote head mounting hardware: 4 each 3/8-18 or M10 studs, nuts, flat and lock washers.
- Ohm meter

Site Preparation

Note: The installation contractor is responsible for compliance with local electrical codes.

The remote luminaire stanchion is provided with 10 feet (3m) of data input cable and 10 feet (3m) power input cable. The stanchion also includes 105 feet (32 m) of data output cable and 105 feet of #16Awg 3-conductor power output cable. Use separate waterproof junction boxes (or a single barriered waterproof junction box) to connect data and AC input cabling to each luminaire. Use terminal strips to connect data wiring inside junction boxes. AC and data output cables connect to terminal strips inside the remote foot assembly.

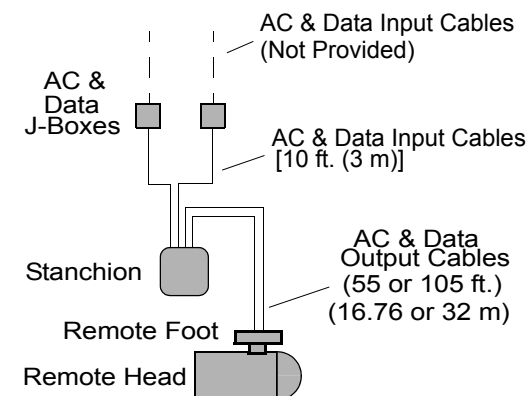

CAUTION: This equipment contains sensitive electronic components that require electrical isolation during installation and operation. DO NOT arc weld on mounting platform with electronics assembly installed in luminaire stanchion.

AC Power requirements

The AR500 luminaire is available in voltages ranging from 100VAC to 277VAC. Each AR500 luminaire requires 900 watts of power at the specified voltage and frequency.

At Voltage	Current at Startup	Current at Run
100V	24A	8A
120V	21A	7A
208V	12A	4A
240V	10A	3.5A
277V	9.75A	3.25A

AC Power and Data wire requirements (not supplied)

AC Power Input:

Wire Gauge: 16AWG 3-conductor (*1.5mm2X3-conductor)
 * European "CE" model

Data Input:

Belden 9729 or equivalent - 22AWG 2-shielded twisted pairs with drain wire.

Stanchion and Head Placement

The **AR500** luminaire remote stanchion and head/foot assembly mount using four sets of 3/8-18 inch (M10) hardware each. When using a concrete platform, the studs should be at least 4 inches (100mm) deep. As shown, the remote head assembly has a limited range of rotations and requires at least eight inches (203mm) clearance behind the head for lamp removal and replacement.

Remote Foot Template

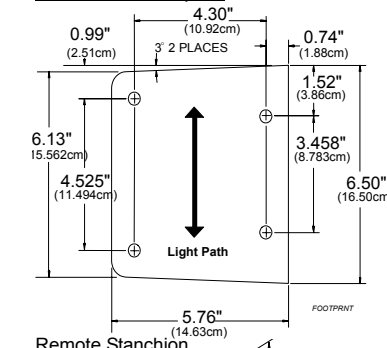

Remote Head Assy

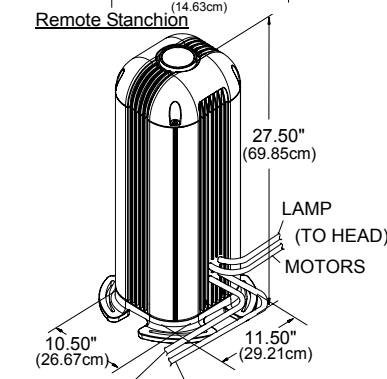
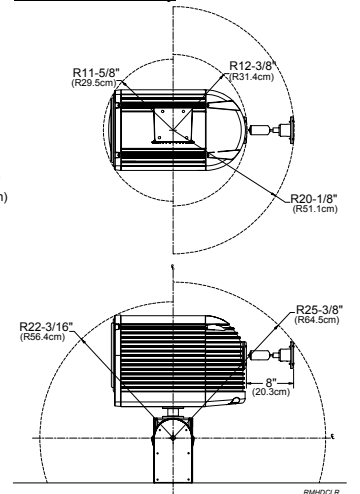

WARNING: Do Not install the luminaire stanchion up side down. The internal electronics are designed to be mounted in an upright position. Serious injury may result if stanchion is mounted incorrectly.



Americas Middleton, Wisconsin • USA • Tel: (+1) 608 831 4116 • Fax: (+1) 608 836 1736 • (+1) 800 775 4382 • service@etcconnect.com
 Europe London • United Kingdom • Tel: +44 (0)20 8896 1000 • Fax: +44 (0)20 8896 2000 • service@etc europe.com
 Asia Hong Kong • Tel: (+852) 2799 1220 • Fax: (+852) 2799 9325 • service@etcasia.com
 International 3030 Laura Lane • Middleton, Wisconsin 53562 • Tel: (+1) 608 831 4116 • Fax: (+1) 608 836 1736 • www.etcconnect.com
 Copyright © 2002 Electronic Theatre Controls, Inc., All Rights Reserved.
 Product information and specifications subject to change • 7091M1003 • Rev D • Released 09/02

Installation

Unpack Shipping Cartons

Note: The stanchion weighs 90 pounds (40.82Kg) or less, depending on voltage configuration. The head enclosure weighs 72 pounds (32.65Kg). Two people are required to install luminaire.

1. Remove stanchion and head assembly from cartons.
2. Locate tool kit (provided).

Install Stanchion

3. Set stanchion on mounting pad in appropriate orientation.
4. Install mounting hardware (not provided). See illustration below.
5. Remove stanchion cap screws using 5/32" Allen wrench
6. At electronics plate, ensure 9-position data-in CPC connector is disconnected.

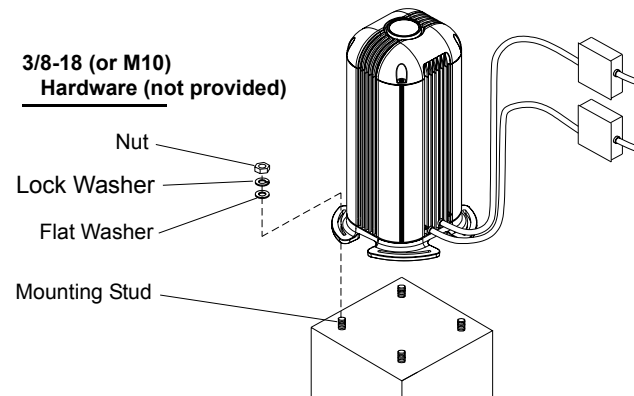

Install Head Assembly

7. At remote foot, use phillips screwdriver to remove screws securing large cover. Remove cover.
8. Remove two neoprene washers located inside the remote foot.
9. Set head assembly on mounting location in required orientation.
10. **Important:** Install two neoprene washers (with metal side up) inside foot as shown in diagram below.
11. Secure assembly with four 3/8 inch (M10) nuts or bolts (not provided).

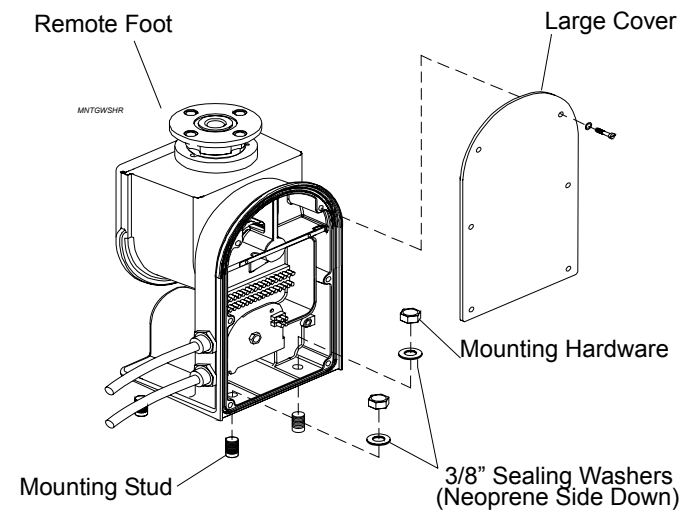

Wiring To Head Assembly

Note: If necessary, loosen terminal strip to install wiring and replace when all wires are terminated.

12. Connect wiring as shown:
 - a. Feed AC output cable (14 AWG, 3-conductor cable) from stanchion through the lower cable entrance. Strip insulation 1/4 inch (6.35mm), and connect to the 2-position terminal strip (connect black wires to black wires and white wires to white wires).
 - b. Secure ground wire under brass washer using green ground screw and secure inside mounting foot.
 - c. Feed data output cable (22 AWG, 16-conductor) from stanchion through the upper cable entrance. Strip shield back four inches (100mm), and strip each wire 1/4 inch (6.35mm). Connect wires to the 16-position terminal strip in the mounting foot. Observe color code (printed sticker inside mounting foot).
 - d. Tighten cable entrance clamps securely.

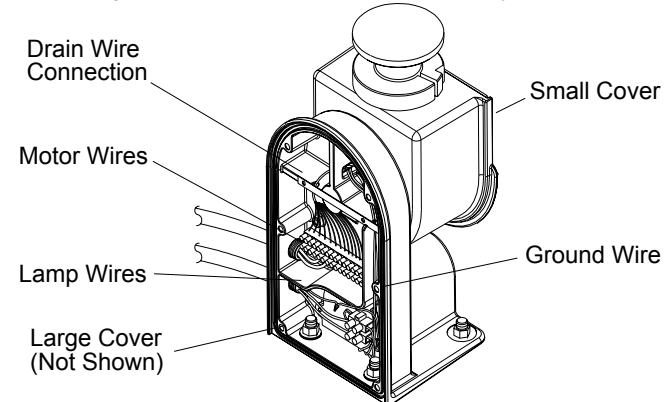

13. Reinstall large cover on remote mounting assembly ensuring tight seal.

Preliminary Focus Adjustment

14. Adjust focus:

CAUTION: Be careful when loosening 3/16 inch Allen screw, 1-1/4 inch nut and 1/2 inch bolt (Steps 14.a. and 14.c.). This unit is heavy and could rotate quickly once it is loosened.

- a. Using 3/16 inch T-handle Allen wrench (provided), loosen Allen head screw on tilt tube clamp slightly if needed.
- b. Using phillips screwdriver, remove three screws and small cover plate.
- c. Using 3/4 inch (or 19mm) socket, slowly loosen 1/2 inch bolt securing top mounting assembly to bottom mounting assembly.
- d. Rotate head assembly to desired angle and pivot remote mount assembly to desired angle.
- e. Tighten 1/2 inch bolt and Allen head screw snug.

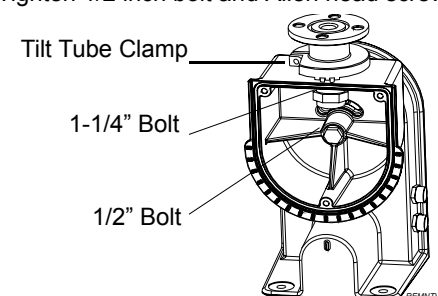

Install Lamp

15. At head assembly, remove rear cap using a Phillips screwdriver. **Ensure O-ring remains in groove of rear cap.**
16. Install lamp in lamp socket. Do not touch the quartz bulb with bare fingers. If touched, clean quartz bulb with alcohol.
17. Reinstall rear cap on head enclosure, **assuring O-ring is still in-place.** Tighten screws in a diagonal cross pattern only until snug. Then tighten screws in same pattern until tight.

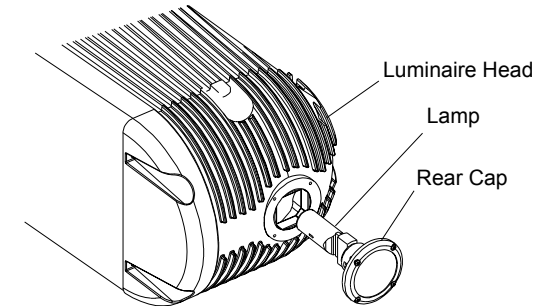

Connect Wiring

WARNING: Remove power from source before connecting junction box wiring.

18. At junction box, connect power wires:
 - a. Run 3-conductor power cable from stanchion to junction box.
 - b. Cut away extra cable and remove approximately four inches (100mm) of cable housing.
 - c. Strip and connect three wires to terminal block as follows:
Black (*Brown) = AC Line
White (*Blue) = AC Neutral
Green (*Grn/Yel) = Ground
* designates European model

19. Connect data wires:

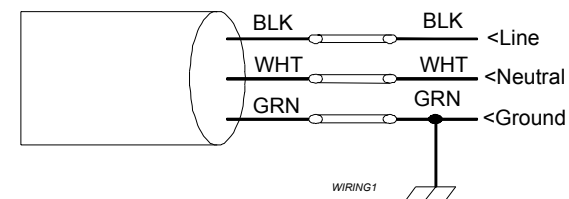

- a. Run data cable from stanchion to junction box.
- b. Cut away extra cable and remove four inches (100mm) of cable housing.
- c. Strip and connect data wires to terminal strip as follows:
White/Red = Positive Data
Black/Green = Negative Data
Drain = Ground

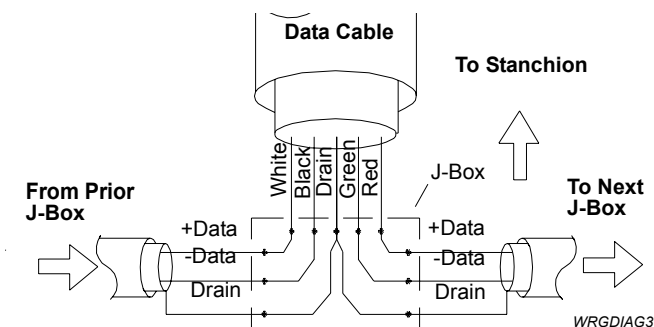

20. If luminaire is at end of data line, install 100 Ohm resistor (provided) between positive (red wire) and negative (green) data line.

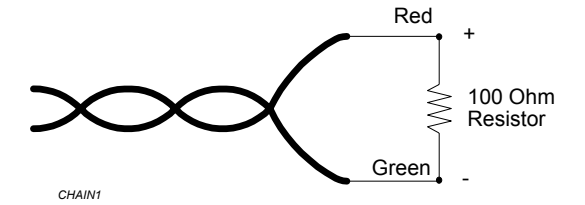

Note: See page 4 for Sample wiring riser.

Wiring Verification

21. To verify data wiring:
 - a. Disconnect data line from controller.
 - b. At beginning of data line, or output of data splitter, use Ohm meter to measure impedance of data line to fixtures.
 - c. Measurement should be approximately 120 Ohms.
 - d. If not, check wiring and termination resistor connection.
 - e. Call tech support (800-688-4116) if problems continue.

Control System

The **AR500** luminaire is controlled with one of two types of electronics plates: DMX only and **Composer** controller. Both systems recognize luminaires according to the luminaire's base address channel setting. The base address channel for each luminaire is assigned using either a three digit thumbwheel (DMX only) or two rotary knobs (**Composer** controller) on the electronics plate.

22. At stanchion electronics plate, set luminaire base address as shown:

DMX Only Address Setting

Each luminaire requires four control channels. Using the three digit thumbwheel, set each luminaire's base address four steps apart, for example:

Luminaire A = Base Address 001, Luminaire B = Base Address 005, Luminaire C = Base Address 009, and so on.

Composer Controller Address Setting

Composer control luminaire versions contain two rotary knobs on the control PCB. One knob controls the ones position and the other controls the tens positions. Unlike the DMX only version, each luminaire base address is set one position apart. For example, Luminaire A = Base Address 1, Luminaire B = Base Address 2...

